

# POWDERCAP™ 821

Handling and weighing of powders

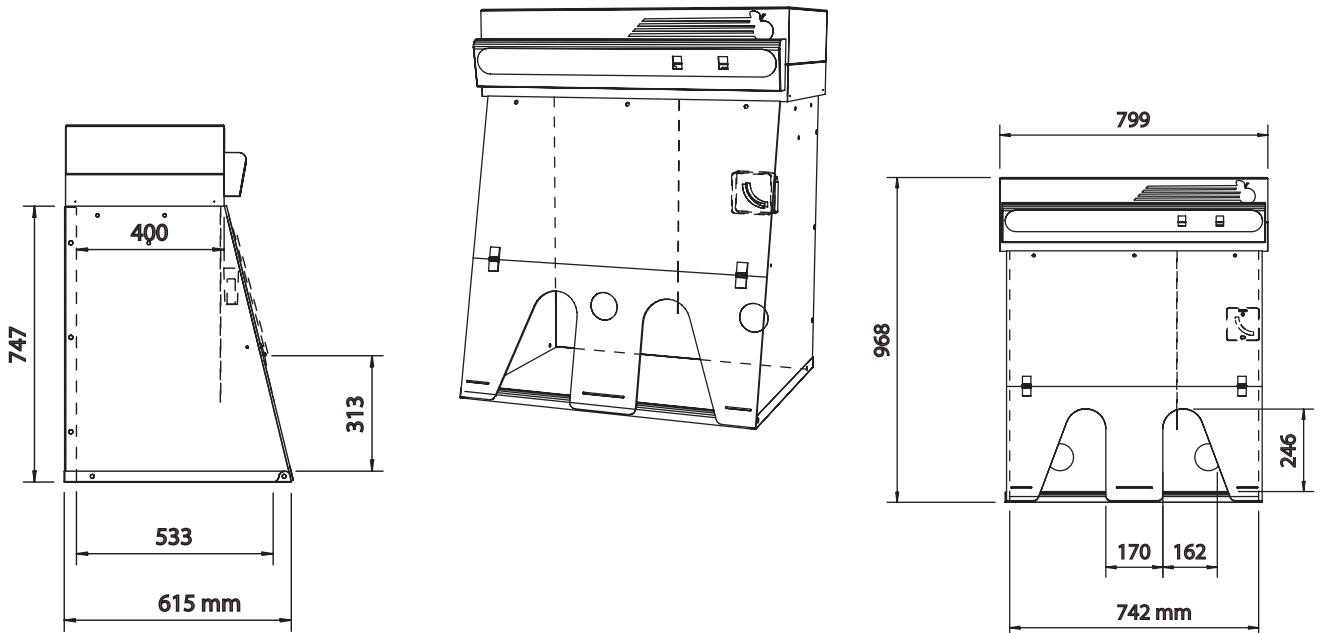

Dimensions <i>mm</i>	Width	Depth	Height
INTERNAL	742	533	747
EXTERNAL	799	615	968

Specifications	POWDERCAP™ 821
Filter type	H 14 HEPA Filter (99,995 % for 0,3 µm)
Average face velocity	0.53 m/s
Internal volume of the enclosure	0.32 m <sup>3</sup>
Total power consumption	49 Watts
Maximum amperage absorbed	0.31 A
Voltage/Frequency	230/50 V / Hz
Blower	1 turbine type
Sound level	55 dB(A)
Shipping weight	65 kg
Fan Failure (monitors the ventilation system)	standard equipment
Temporary ventilation interruption system	standard equipment
Air Velometer (controls the air velocity)	standard equipment
Work surface	standard equipment
Lighting (1x 11W)	option n°58
Clear back panel	option E
MOBICAP™ rolling cart	Option Mobicap™ 821
Work surface with a cutout	Option 54